

Introduction

Thank you for purchasing the Hurricane ES. Please read our Quick Start Guide to understand and ensure proper, effective and responsible use of the Hurricane ES.

Safety Precautions

Please ensure you have read and fully understood the safety precautions before operating this appliance.

- Instructions for use of this product will vary depending on chemical applications. Always read the product label when preparing your solution.
- To prevent injury always wear personal protective equipment while fogging. This includes, but is not limited to, safety glasses and a facemask or respirator.
- This appliance is to be kept out of reach from children. However, it can be used by children aged 8 years and above, as well as persons with reduced physical, sensory or mental capacities or lack of experience and knowledge, provided they have been given supervision or instruction concerning use of the appliance in a safe way, and understand the hazards involved.
- Children should not play with the appliance, and cleaning and user maintenance should not be made by children without supervision.
- Children should be supervised to ensure they do not play with the appliance.
- The appliance is not to be used in locations where flammable vapour or explosive dust is likely to exist.

Please take note of the below diagram to familiarise yourself with the design and structure of the unit:

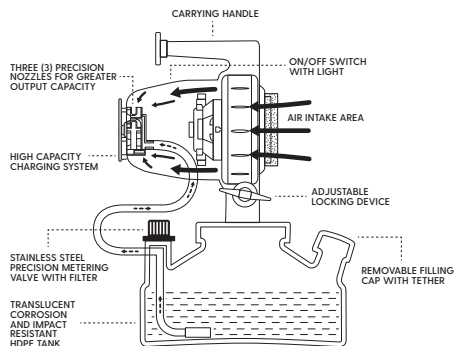

General

- Hold the appliance when operating so that your hand remains in contact with the grounding strip located underneath the carrying handle.
- Leaving the appliance unattended while in operation can cause a build-up of electrostatic charge that can cause a static shock.
- Please also note that objects in the vicinity of the appliance may also develop a small electrostatic charge during operation.

Power Supply

- The Hurricane ES is designed to operate from a three wire power system in which one of the wires is a safety ground.
- Please use a grounded extension lead plugged into a grounded electrical supply.
- Extension leads should be sized appropriately for the electrical current demand. Leads vary in rating, based on the amperage they can safely carry and the wattage they can handle (both determined by the gauge of the wire.) Please ensure the amperage and wattage rating is correct for the appliance.

Operation

- Turn the flow valve to the OFF position after each fogging application while the motor is still operating to allow the clearing of the lines.
- Ensure you are wearing appropriate PPE when operating this machine.
- Only use water-based formulations with this machine. Remove the filling cap to pour formulation into the tank.
- Use a 3-pin grounded extension lead that is rated accordingly for voltage (120 V/240 V).
- Do not block the air intake area.
- Avoid tampering with the output nozzle, 3-prong electrodes and charging ring.
- The machine should not be left operating unattended, and for the most efficient application it should not be left stationary.
- Users should hold the appliance and manually cover the designated fogging areas.

Flow Rate Information

Please use the below table as a reference for the flow rate of the Hurricane ES.

Metering Valve Setting	Hurricane ES Flow Rate And Droplet Size	
	Flow Rate Oz/Min to mL/Min	Droplet Size Microns - Volume Media Diameter
#1	6.0 to 60	10 - 20 MICRONS
#2	7.5 to 90	20 - 30 MICRONS
#3	9.5 to 120	30 - 50 MICRONS

- Thicker viscosity liquids will flow at lower rates than demonstrated in the above table, and produce a bigger droplet size.
- Adjusting the valve will regulate flow rate.
- When the valve is turned clockwise, flow rate will reduce; when turned anti-clockwise, flow rate will increase.

Maintenance

- The formulation tank should be cleaned periodically by using hot water with a detergent solution.
- You should fully open the valve and operate the machine for 3 to 5 minutes. This will flush the solution through the valve, lines and nozzle.
- Clean the Air Intake Filter after each application. If the filter becomes saturated while the machine is in operation, switch it off and clean the filter.

Wiring Instructions

The wires in the mains lead are coloured in accordance with the following code:

BLUE = NEUTRAL

BROWN = LIVE

YELLOW & GREEN = EARTH

As the colours of the wire in the mains lead of this appliance may not correspond with the colour marking identifying the terminals on your plug, proceed as follows:

- The wire which is coloured BLUE must be connected to the terminal which is marked with the letter N.
- The wire which is coloured BROWN must be connected to the terminal which is marked with the letter L.
- The wire which is coloured YELLOW & GREEN must be connected to the terminal which is marked with the letter E or the symbol ⊕

For UK

This appliance is supplied fitted with a BS1363 mains plug and a BS1362 5A fuse. If this plug is removed from the appliance, please ensure it is disposed of safely as a disconnected plug is dangerous if reconnected to the mains. If any other type of plug is used, a 5A fuse must be fitted.

For EU

This appliance is supplied fitted with a Schuko mains plug. If this plug is removed from the appliance, please ensure it is disposed of safely as a disconnected plug is dangerous if reconnected to the mains.

For private households: Information on Disposal for Users of WEEE

This symbol (Figure. 1) on the product(s) and / or accompanying documents means that used electrical and electronic equipment (WEEE) should not be mixed with general household waste.



Figure. 1

For proper treatment, recovery and recycling, please take this product (s) to designated collection points where it will be accepted free of charge.

Alternatively, in some countries, you may be able to return your products to your local retailer upon purchase of an equivalent new product.

Disposing of this product correctly will help save valuable resources and prevent any potential negative effects on human health and the environment, which could otherwise arise from inappropriate waste handling.

Please contact your local authority for further details of your nearest designated collection point.

Penalties may be applicable for incorrect disposal of this waste, in accordance with your national legislation.

For professional users in the European Union

If you wish to discard electrical and electronic equipment (EEE), please contact your dealer or supplier for further information.

For disposal in countries outside of the European Union

This symbol is only valid in the European Union (EU). If you wish to discard of this product, please contact your local authorities or dealer and ask for the correct method of disposal.



**2 Year
Guarantee**